

CWD556

CWD880

CWD880H

CWD2208

CWD3M883

CWD3M890

CWD3M2208

CWD556

Digital Stepper Drive

Descriptions:

The CWD556 is a new generation digital 2-phase stepper motor driver, based on a 32-bit DSP processor, combination of the anti-resonance, low noise, micro-step and low temperature rise technology significantly improve the performance of the stepper motor, has low noise, small vibration, low temperature rise and high-speed torque. The driver use online adaptive PID technology, without manual adjustment can be automatically generated optimal parameters for different motors, and achieve the best performance.

Supply voltage range from 24VDC to 50VDC, suitable for driving various 2-phase hybrid stepping motors which phase current below 5.6A. The microstep can be set from full step to 51200steps/rev and the output current can be set from 2.1A to 5.6A; with automatic idle-current reduction, self-test, overvoltage, under-voltage and over-current protection.

Features:

- High-performance, low price;
- micro-step;
- Automatic idle-current reduction;
- Optical isolating signals I/O;
- Max response frequency up to 200Kpps;
- Low temperature rise, smooth motion;
- Online adaptive PID technology.

Applications:

Suitable for a variety of large-scale automation equipments and instruments. For example: labeling machine, cutting machine, packaging machine, plotter, engraving machine, CNC machine tools and so on. It always performs well when applied for equipment which requires for low-vibration, low-noise, high-precision and high-velocity.



Electrical Specifications:

Parameter	Min	Typical	Max	Unit
Input Voltage(DC)	20	-	50	VDC
Output current	0	-	5.6	A
Pulse Signal Frequency	0	-	200	KHZ
Logic Signal Current	7	10	16	MA

Current Setting:

Peak	RMS	SW1	SW2	SW3
Default		off	off	off
2.1A	1.5A	on	off	off
2.7A	1.9A	off	on	off
3.2A	2.3A	on	on	off
3.8A	2.7A	off	off	on
4.3A	3.1A	on	off	on
4.9A	3.5A	off	on	on
5.6A	4.0A	on	on	on

Standstill Current Setting:

SW4 is used for standstill current setting. OFF meaning that the standstill current is half of the dynamic current; and ON meaning that standstill current is the same as the selected dynamic current. Usually the SW4 is set to OFF, in order to reduce the heat of the motor and driver.

Microstep Setting:

Step/Rev	SW5	SW6	SW7	SW8
Default	on	on	on	on
800	off	on	on	on
1600	on	off	on	on
3200	off	off	on	on
6400	on	on	off	on
12800	off	on	off	on
25600	on	off	off	on
51200	off	off	off	on
1000	on	on	on	off
2000	off	on	on	off
4000	on	off	on	off
5000	off	off	on	off
8000	on	on	off	off
10000	off	on	off	off
20000	on	off	off	off
40000	off	off	off	off

Control Signal Connector:

Control Signal connector	
Name	Description
PUL+	Pulse signal positive
PUL-	Pulse signal negative
DIR+	Direction signal positive
DIR-	Direction signal negative
ENA+	Enable signal positive, usually left unconnected(enable)
ENA-	Enable signal negative, usually left unconnected(enable)

Power and Motor Connector:

GND	Power Ground
+Vdc	Power supply, +20~+50 VDC
A+	Motor phase A
A-	
B+	Motor phase B
B-	

Typical Connection:

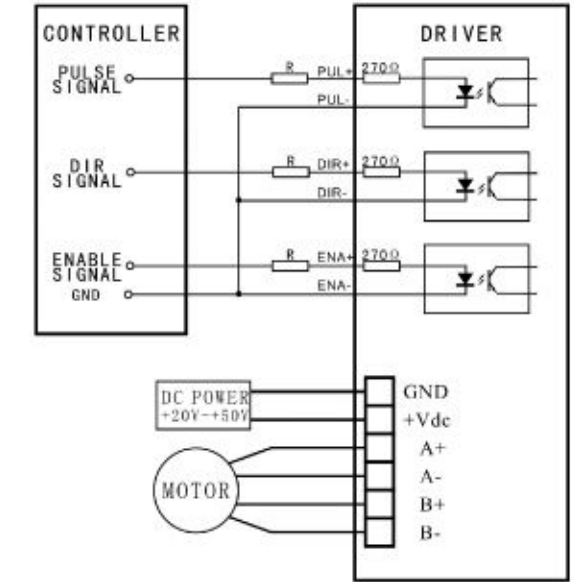

VCC	R
5V	0
12V	680Ω
24V	1.8KΩ

Mechanical Specifications:

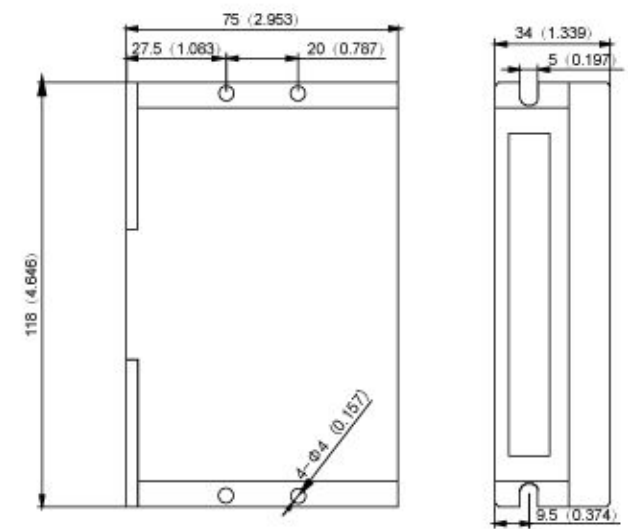

unit: mm(inch), 1 inch = 25.4mm

CWD556

CWD880

CWD880H

CWD2208

CWD3M883

CWD3M890

CWD3M2208