

ø 239 x 109 mm

400 Hz Axial Fans

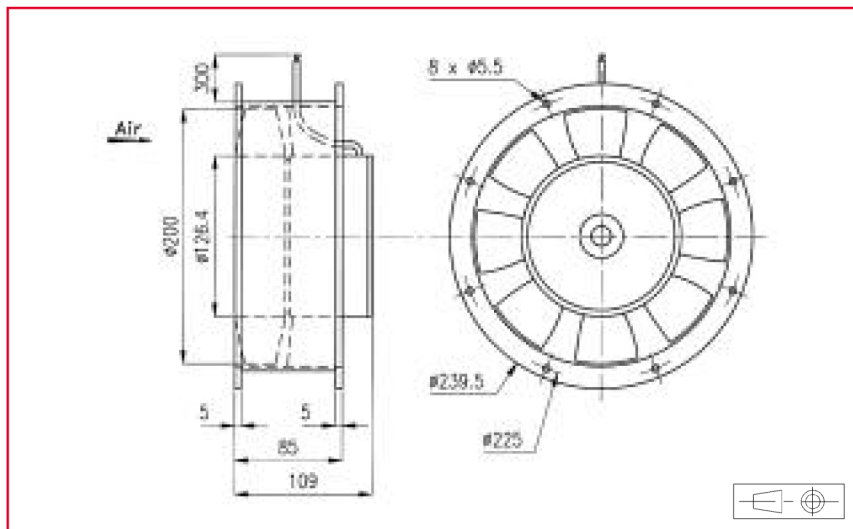

Approvals

See selection guide pages 15 to 26
GAMT 1 listed

Life expectancy

L-10 LIFE AT 40°C:
35 000 hours
For more details, see page 14

400 Hz Motor

Housing material: Aluminium
Impeller material: Aluminium
Weight: 4,7 kg
Bearing system: ball bearings

Connection: flying leads

Available with:
- safety switch

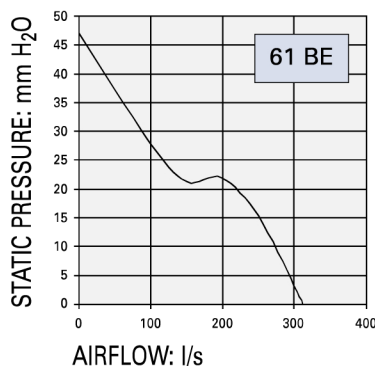

Part number	Nominal voltage	Airflow	Noise level	Nominal speed	Phases	Capacitor	Input power	Nominal current	Starting current	Operating temperature	
	V									l/s	dB(A)
61BE0160C13	200	310	68	3500	3		126	1030	2100	- 10	70
	200	310	68	3500	1	2	134	840	1600	- 10	70
61BE0162C13	115	310	68	3500	3		126	1800	3650	- 10	70
	115	310	68	3500	1	5,7	134	1450	2800	- 10	70

Additional versions:

Salt spray protected - shock and vibration protected - marine specifications - wide temperature range

Accessories:

See pages: 154, 156, 158 and 162