

# GF-200B CENTRIFUGAL FAN

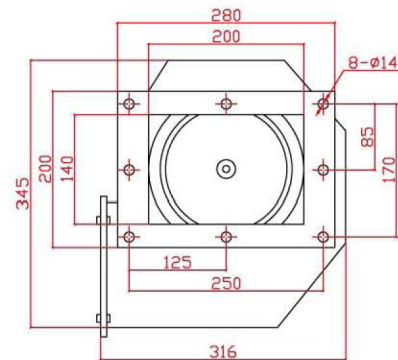

**Size:** 420mm×316mm×345mm  
**Motor:** Capacitor induction  
**Bearing:** Ball  
**Impeller:** Metal, Ø200mm×90mm  
**Frame:** Steel with plastic-coated  
**Weight:** 11.6kg  
**Life:** 30000hours  
**Operation Temperature:** -20°C~+50°C

Model	Voltage VAC	Freq. Hz	Current A	Power W	Speed RPM	Air flow m <sup>3</sup> /hr	Noise dB
GF-200B	220	56/60	1.42/1.51	310/330	1400/1250	1000/860	≤66

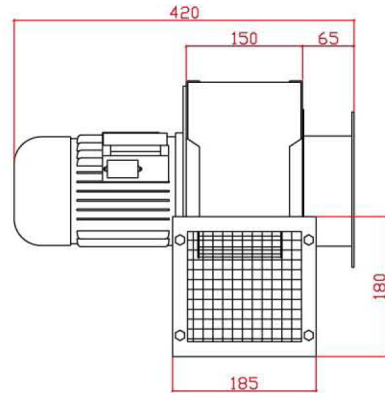